

# Double-Wall Cylinders/ Repairable Stainless Steel Cylinders

Double-Wall Cylinders

6.3-6.15

Repairable Stainless Steel  
Cylinders

6.16-6.24

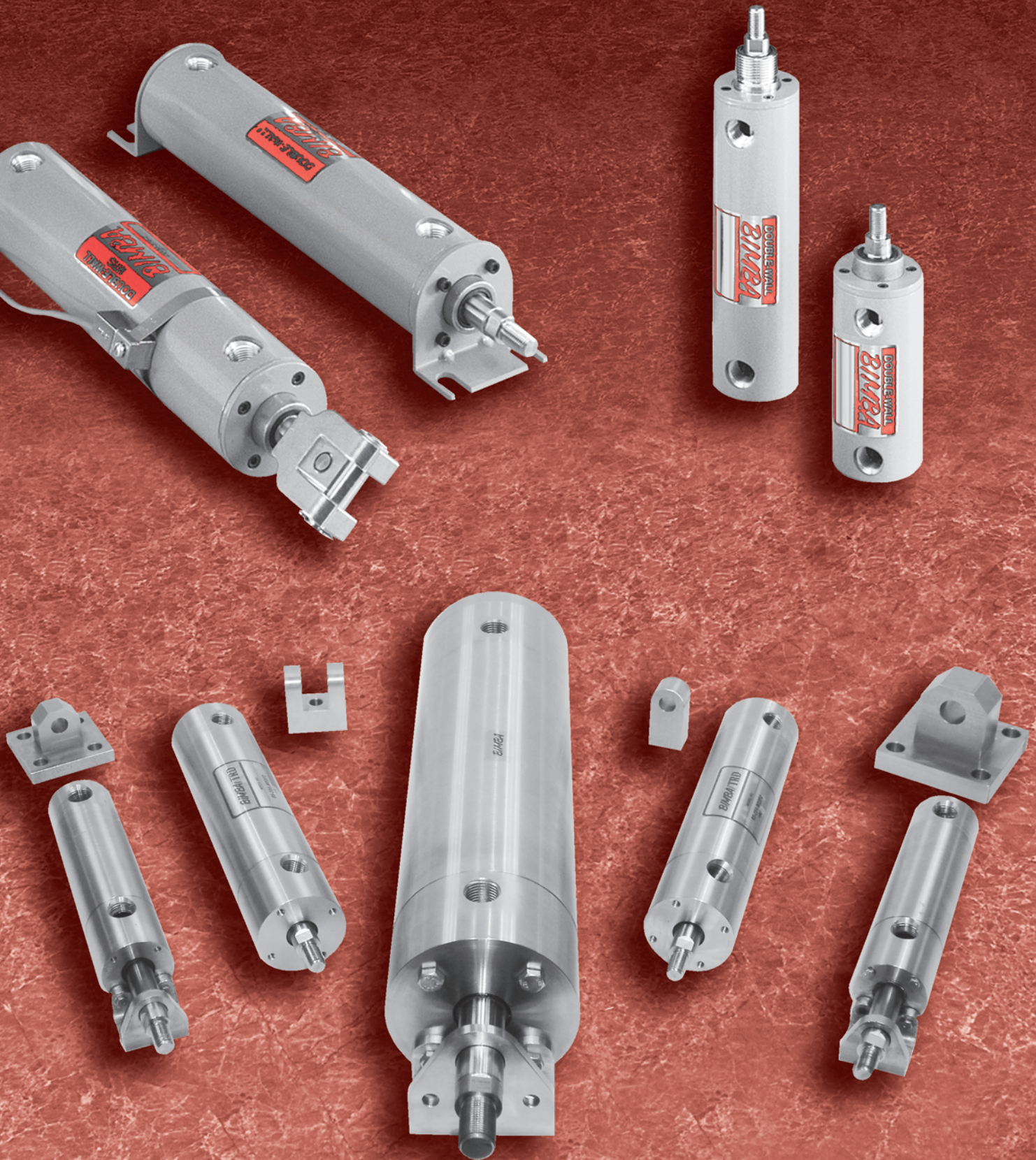

# Bimba Double-Wall Cylinders

The Bimba Double-Wall® Cylinder Does It All !

*One Basic cylinder converts into six NFPA mounting styles*

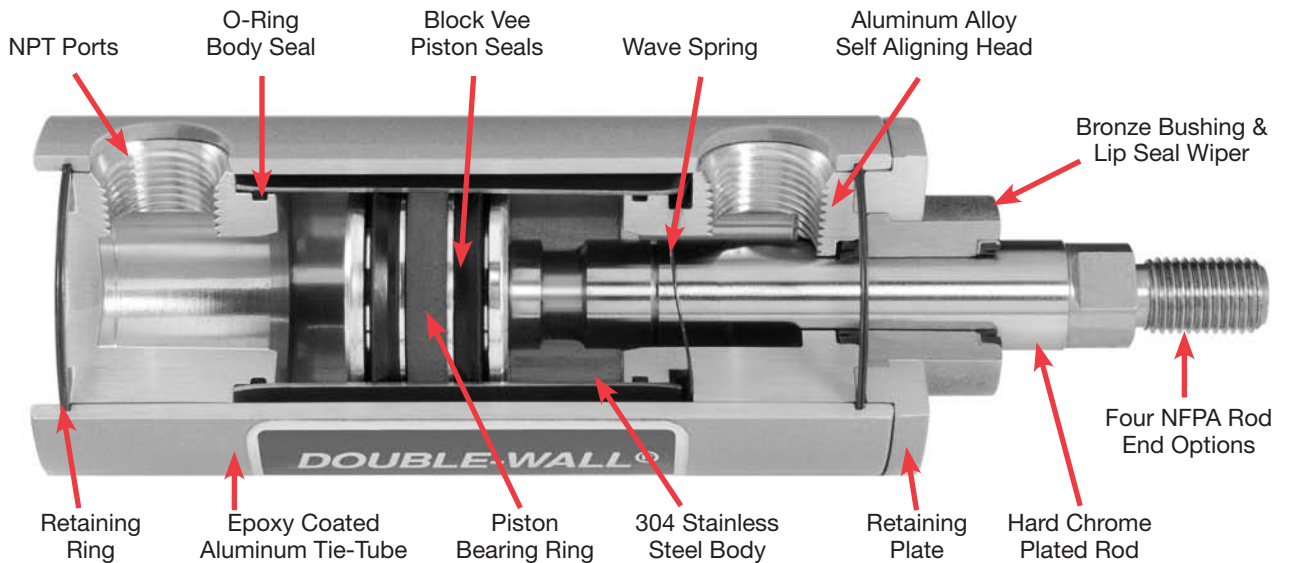
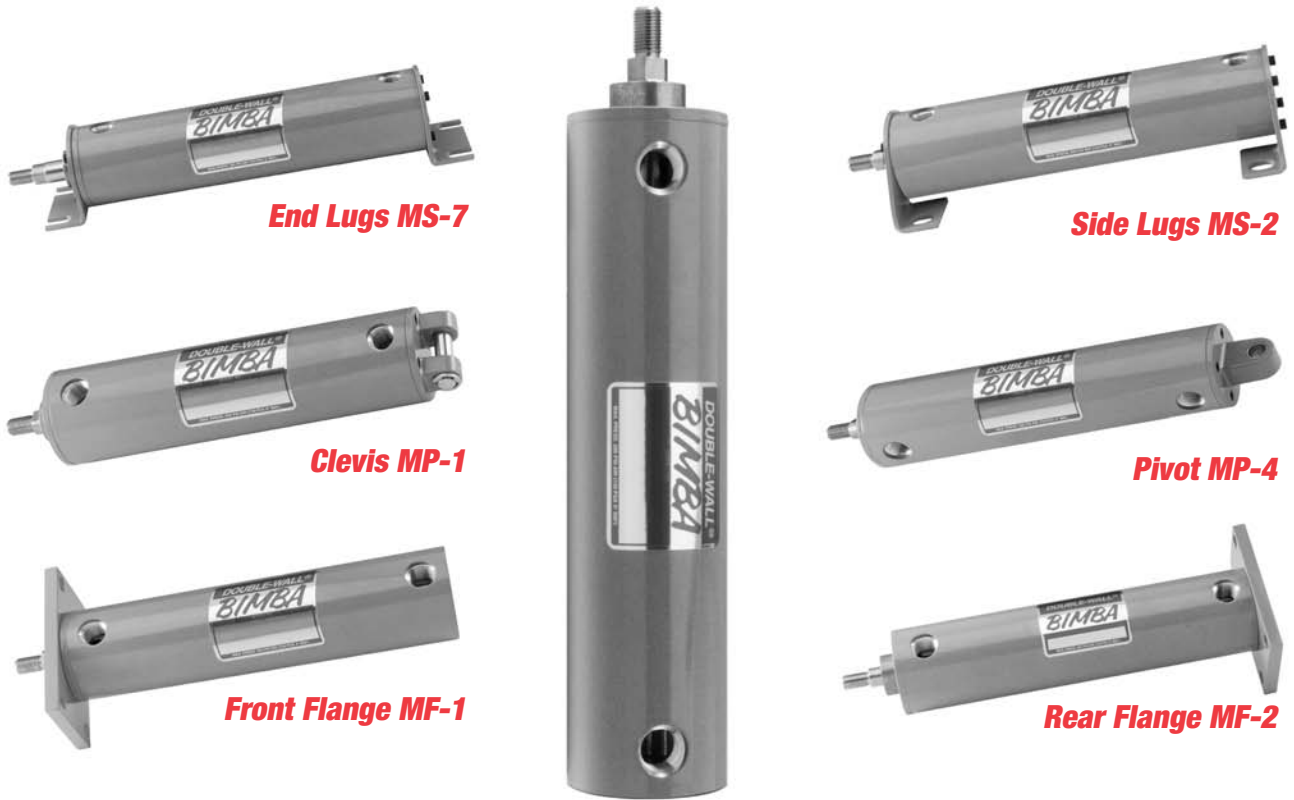

# Bimba Double-Wall® Cylinders

## How to Order

The Model Number for Double-Wall® cylinders consists of three alphanumeric clusters. These designate product type, bore size and stroke length, and options (options are written in the following order: rod end options, and special options with extra extension last). Mounting kits must be ordered as a separate item, and are shown with their respective bore sizes starting on page 6.6. Please refer to the charts below for an example of model number DWC-1710-2V. This is a 1-1/2" bore, 10" stroke, Double-Wall cushioned cylinder with a small male one piece rod end and high temperature option.

### DWC - 17 10 - 2 V

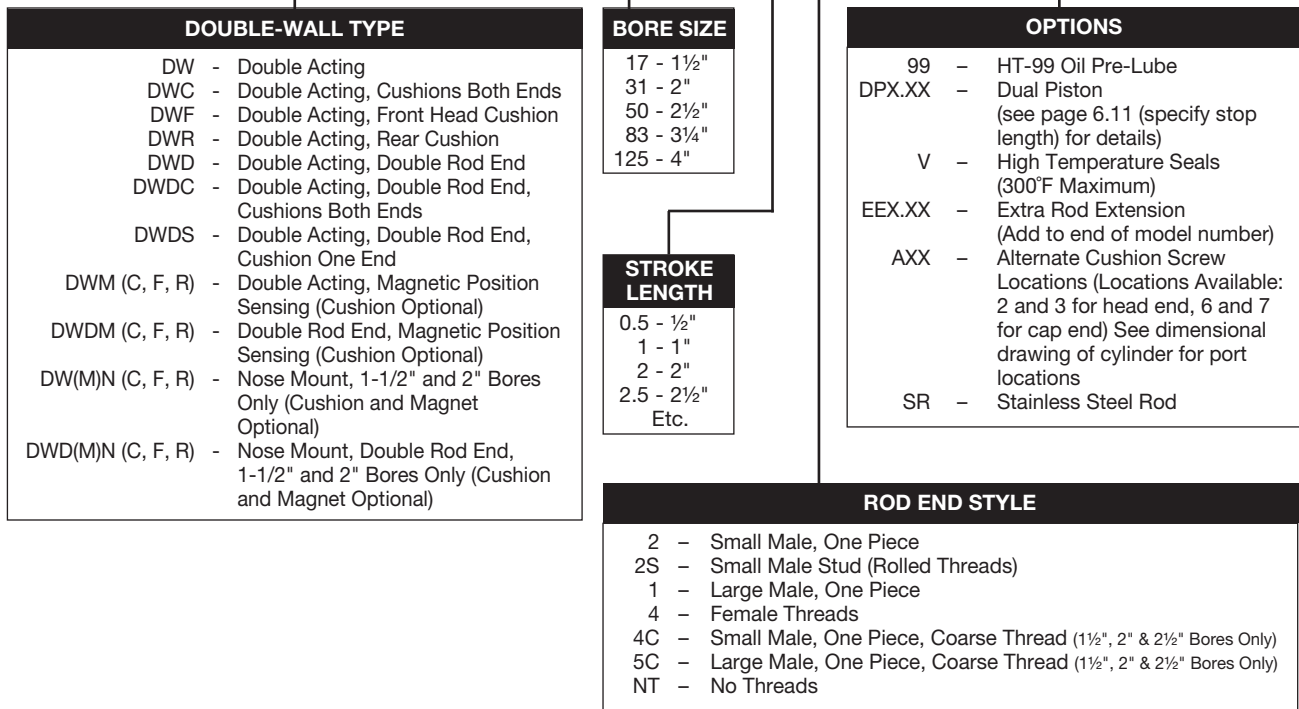

(See page 6.5 for dimensions)

# Bimba Double-Wall® Cylinders

## List Prices

Basic Model	Base Price	Stroke Adder <sup>1</sup> (per inch)	Mounting Options	Options						
			2S - Small Male Stud	C Per end (Prefix C)	DP <sup>2</sup>	EE (each 1/2" each end)	M (Prefix M)	SR	V	V (with cushions per end) <sup>3</sup>
<b>1-1/2" Bore</b>										
DW - 17	\$93.30	\$ 3.65	\$ 6.55	\$16.30	\$16.95	\$ 1.45	\$44.45	\$11.00	\$49.25	\$55.90
DWD - 17	117.85	5.50	12.90	16.30	N/A	2.80	44.45	16.55	66.00	55.90
DWN - 17	110.75	4.45	7.05	17.45	18.15	1.60	47.60	11.80	52.70	59.85
DWDN - 17	136.90	7.75	13.85	17.45	N/A	3.00	47.60	17.75	70.65	59.85
<b>2" Bore</b>										
DW-31	105.95	3.90	6.55	17.50	17.95	1.45	44.45	11.00	61.20	62.95
DWD-31	136.75	6.05	12.90	17.50	N/A	2.80	44.45	16.55	78.10	62.95
DWN-31	124.35	5.35	7.05	18.75	19.25	1.60	47.60	11.80	65.50	67.40
DWDN-31	156.60	8.75	13.85	18.75	N/A	3.00	47.60	17.75	83.60	67.40
<b>2-1/2" Bore</b>										
DW-50	128.30	4.65	7.05	20.10	21.00	1.60	47.60	11.80	65.95	68.90
DWD-50	160.50	8.15	13.85	20.10	N/A	3.00	47.60	17.75	84.55	68.90
<b>3-1/4" Bore</b>										
DW-83	176.30	6.70	15.35	26.85	36.60	2.10	53.50	22.10	71.15	79.20
DWD-83	217.50	9.90	30.40	26.85	N/A	4.05	53.50	33.05	88.65	79.20
<b>4" Bore</b>										
DW-125	213.20	7.80	15.35	28.50	43.15	2.10	53.50	22.10	95.65	92.85
DWD-125	275.20	12.60	30.40	28.50	N/A	4.05	53.50	33.05	110.55	92.85

### Mounting Kits

Model	1-1/2"	2"	2-1/2"	3-1/4"	4"
MSL -	\$22.55	\$27.95	\$33.70	\$41.90	\$53.70
MEL -	15.15	18.30	22.55	31.70	32.75
MC -	20.05	22.65	25.35	33.10	36.00
MP -	16.95	18.70	20.20	27.10	30.05
MFFA (Aluminum)	20.20	22.65	26.70	35.40	43.95
MFFS (Steel)	28.55	31.10	34.10	44.90	50.90
MFRA (Aluminum)	20.20	22.65	26.70	35.40	43.95
MFRS (Steel)	28.55	31.10	34.10	44.90	50.90

### Repair Kits

Kit Number	1-1/2"	2"	2-1/2"	3-1/4"	4"
K-A	\$ 9.20	\$ 9.20	\$ 9.20	\$16.50	\$16.50
K-B	14.05	18.80	22.05	30.30	44.05
K-C	7.25	7.25	7.25	10.50	10.50
K-D	18.15	24.10	28.60	38.25	54.75
K-P-M	38.15	39.95	40.20	49.35	58.20
HT-99-7CC	4.55				
MAG-G-3CC	7.35				

See pages 6.13-6.14 for details.  
Consult factory for pricing on individual repair parts.

### Accessories

Models	Description	List Price
<b>1-1/2", 2", and 2-1/2" bores</b>		
ARE-1	Rod Eye	\$21.15
ARC-1	Rod Clevis	22.40
APB-1	Pivot Bracket	21.35
ACB-1	Clevis Bracket	23.05
ARS-1	Rod Stud	7.00
APP-1	Pivot Pin	7.05
D-154	Rod Nut	0.60
D-98	Rod Nut	0.70
D-17920	Nose mount foot bracket	11.65
D-1331	Nose mount mounting nut	2.85

Models	Description	List Price
<b>3-1/4" and 4" bores</b>		
ARE-2	Rod Eye	\$30.50
ARC-2	Rod Clevis	37.85
APB-2	Pivot Bracket	33.30
ACB-2	Clevis Bracket	41.75
ARS-2	Rod Stud	15.45
APP-2	Pivot Pin	11.25
D-3556	Rod Nut	1.00
D-2545	Rod Nut	1.50
D-17920	Nose mount foot bracket	11.65
D-1331	Nose mount mounting nut	2.85

# Bimba Double-Wall® Cylinders

## Dimensions (in.)

### Rod Thread – 2, 2S, 1, 4C, 5C

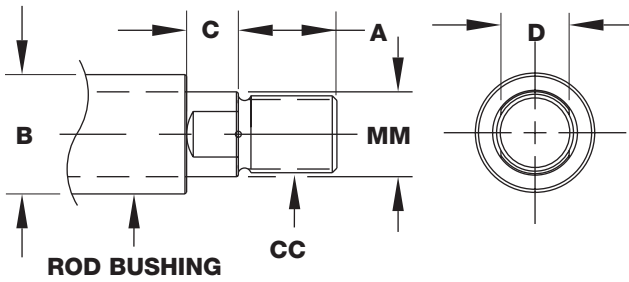

### Rod Thread – 4

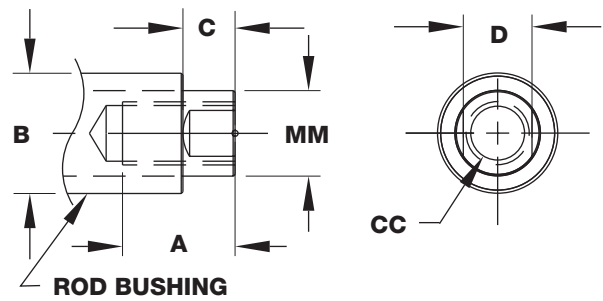

### Rod End (1½", 2" and 2½" Bores)

Rod End Style	A	B	C	CC	D	MM
2	.75	1.12	.38	7/16-20 UNF	.5	.62
2S	.75	1.12	.38	7/16-20 UNF	.5	.62
1	.75	1.12	.38	1/2-20 UNF	.5	.62
4 (tapped)	.75	1.12	.38	7/16-20 UNF	.5	.62
4C	1.25	1.00	.19	1/2-13 UNC	.5	.62
5C	1.25	1.00	.19	5/8-11 UNC	.5	.62

### Rod End (3¼", 4" Bores)

Rod End Style	A	B	C	CC	D	MM
2	1.12	1.5	.5	3/4-16 UNF	.88	1.00
2S	1.12	1.5	.5	3/4-16 UNF	.88	1.00
1	1.12	1.5	.5	7/8-14 UNF	.88	1.00
4 (tapped)	1.12	1.5	.5	3/4-16 UNF	.88	1.00

### Double-Wall (no mounting)

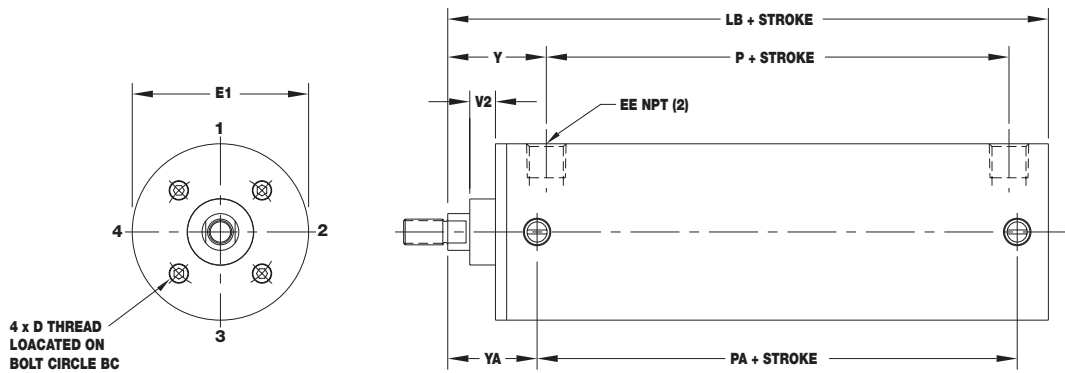

Bore	LB	P	Y	V2	EE	YA	PA	E1	D	D depth	BC
1-1/2"	4.62	2.28	1.67	.44	3/8 NPT	1.52	2.58	2.00	#6-32	0.51	1.48
2"	4.62	2.28	1.67	.44	3/8 NPT	1.52	2.58	2.34	#8-32	0.66	1.75
2-1/2"	4.75	2.41	1.67	.44	3/8 NPT	1.52	2.70	2.94	#10-24	0.69	2.00
3-1/4"	5.63	2.62	2.19	.74	1/2 NPT	2.00	3.00	3.69	5/16-18	0.75	2.83
4"	5.63	2.62	2.19	.74	1/2 NPT	2.00	3.00	4.44	5/16-18	0.75	2.83

# Bimba Double-Wall® Cylinders

## Side Lug Mount (NFPA MS-2) (in.)

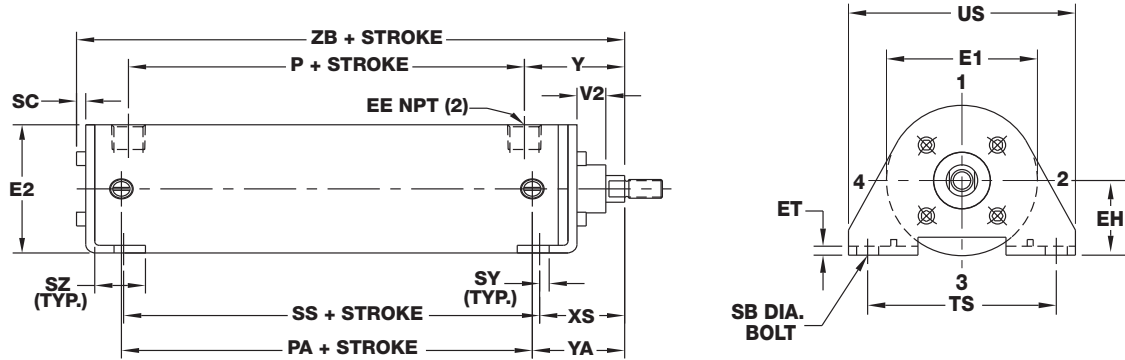

Bore	Kit	ZB	P	SS	PA	V2	Y	EE	SY	XS	YA	SC	E2	SZ	US	E1	EH	ET	TS	SB
1-1/2"	MSL-17	4.90	2.28	2.87	2.58	.31	1.67	3/8 NPT	0.19	1.38	1.52	.14	2.00	1.00	3.51	2.00	1.00	.13	2.75	.38
2"	MSL-31	4.92	2.28	2.87	2.58	.31	1.67	3/8 NPT	0.19	1.38	1.52	.16	2.34	1.00	4.01	2.34	1.25	.13	3.25	.38
2-1/2"	MSL-50	5.12	2.41	3.00	2.70	.26	1.67	3/8 NPT	0.19	1.38	1.52	.19	3.00	1.00	4.51	2.94	1.49	.18	3.75	.38
3-1/4"	MSL-83	6.11	2.62	3.25	3.00	.49	2.19	1/2 NPT	0.16	1.88	2.00	.23	3.75	1.25	5.76	3.69	1.87	.25	4.75	.50
4"	MSL-125	6.17	2.62	3.25	3.00	.43	2.19	1/2 NPT	0.16	1.88	2.00	.23	4.50	1.25	6.51	4.44	2.24	.31	5.50	.50

## End Lug Mount (NFPA MS-7) (in.)

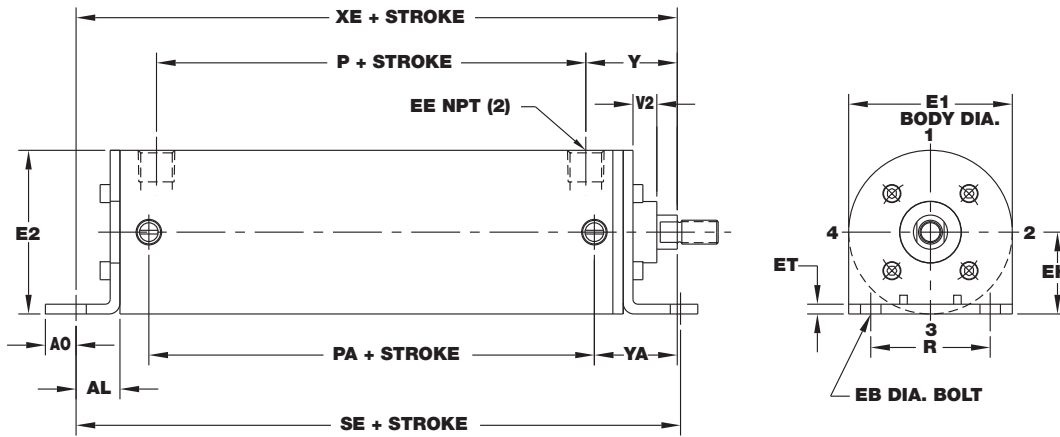

Bore	Kit	XE	P	PA	SE	V2	Y	EE	YA	A0	AL	E2	E1	EH	ET	EB	R
1-1/2"	MEL-17	5.38	2.28	2.58	5.12	.31	1.67	3/8 NPT	1.52	.26	.75	2.00	2.00	1.00	.13	.25	1.43
2"	MEL-31	5.56	2.28	2.58	5.50	.31	1.67	3/8 NPT	1.52	.32	.94	2.34	2.34	1.25	.13	.31	1.84
2-1/2"	MEL-50	5.81	2.41	2.70	5.88	.26	1.67	3/8 NPT	1.52	.30	1.07	3.00	2.94	1.49	.18	.31	2.19
3-1/4"	MEL-83	6.50	2.62	3.00	6.00	.49	2.19	1/2 NPT	2.00	.38	1.18	3.75	3.69	1.87	.25	.38	2.76
4"	MEL-125	6.63	2.62	3.00	6.25	.43	2.19	1/2 NPT	2.00	.37	1.32	4.50	4.44	2.24	.31	.38	3.32

# Bimba Double-Wall® Cylinders

## Clevis Mount (NFPA MP-1) (in.)

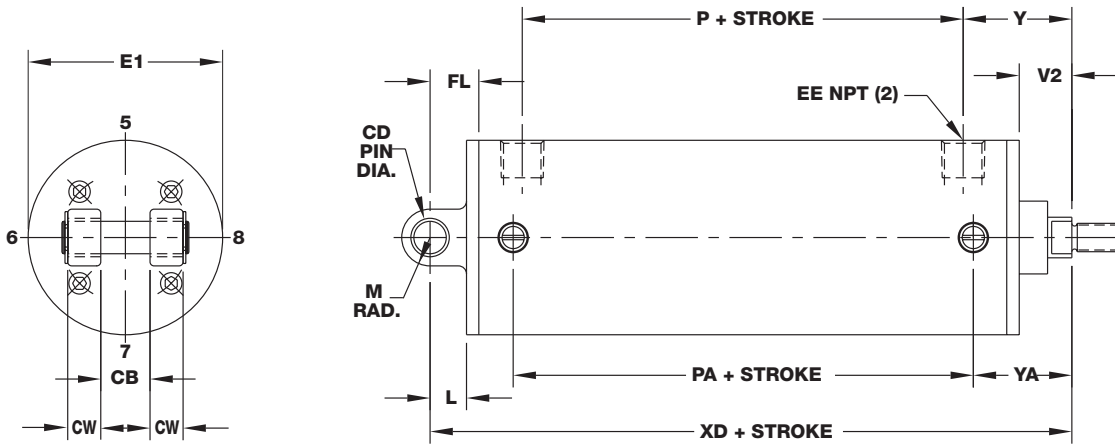

Bore	Kit	P	PA	XD	Y	V2	EE	YA	FL	CD	M	L	E1	CB	CW
1-1/2"	MC-17	2.28	2.58	5.38	1.67	.82	3/8 NPT	1.52	.75	.50	.44	.56	2.00	.76	.51
2"	MC-31	2.28	2.58	5.38	1.67	.82	3/8 NPT	1.52	.75	.50	.44	.56	2.34	.76	.51
2-1/2"	MC-50	2.41	2.70	5.50	1.67	.82	3/8 NPT	1.52	.75	.50	.50	.56	2.94	.76	.51
3-1/4"	MC-83	2.62	3.00	6.88	2.19	1.24	1/2 NPT	2.00	1.26	.75	.69	.88	3.69	1.26	.62
4"	MC-125	2.62	3.00	6.88	2.19	1.24	1/2 NPT	2.00	1.26	.75	.69	.88	4.44	1.26	.62

## Pivot Mount (NFPA MP-4) (in.)

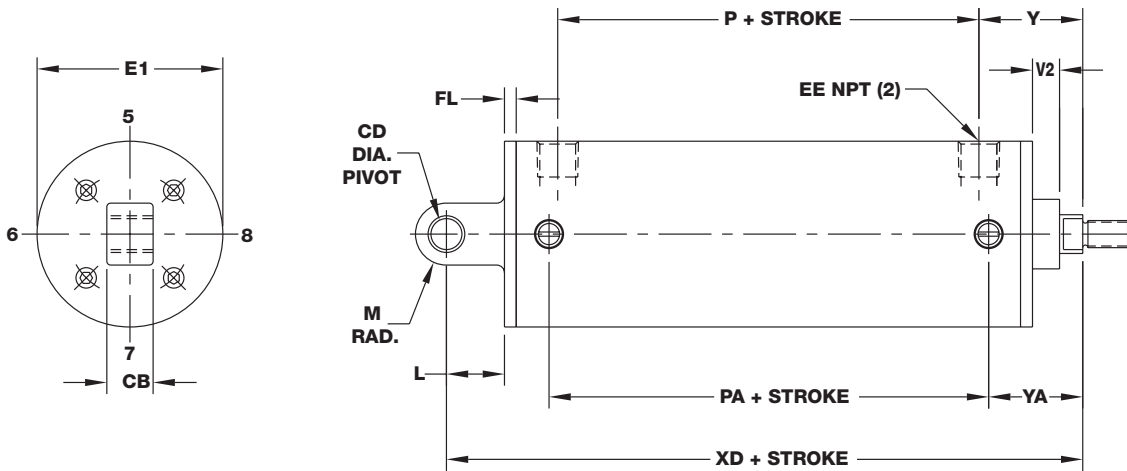

Bore	Kit	P	PA	XD	Y	V2	EE	YA	FL	CD	M	L	E1	CB
1-1/2"	MP-17	2.28	2.58	5.75	1.67	.44	3/8 NPT	1.52	.19	.50	.50	.93	2.00	.75
2"	MP-31	2.28	2.58	5.75	1.67	.44	3/8 NPT	1.52	.19	.50	.50	.93	2.34	.75
2-1/2"	MP-50	2.41	2.70	5.87	1.67	.44	3/8 NPT	1.52	.19	.50	.50	.93	2.94	.75
3-1/4"	MP-83	2.62	3.00	7.50	2.19	.74	1/2 NPT	2.00	.50	.75	.69	1.38	3.69	1.25
4"	MP-125	2.62	3.00	7.50	2.19	.74	1/2 NPT	2.00	.50	.75	.69	1.38	4.44	1.25

# Bimba Double-Wall® Cylinders

## Front Flange Mount (NFPA MF-1) (in.)

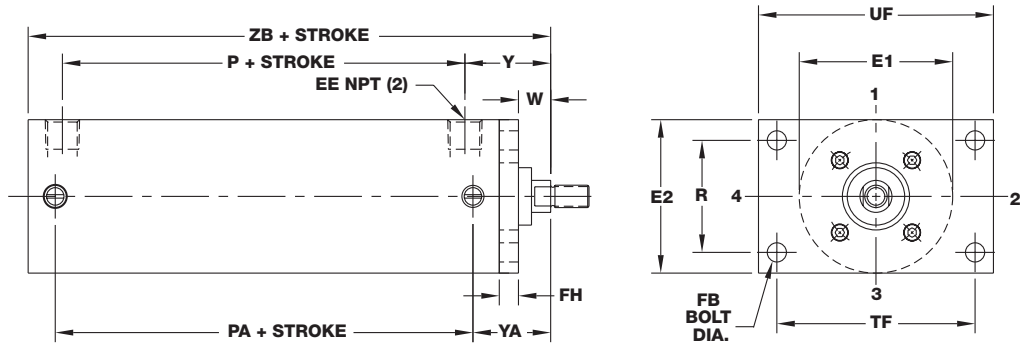

Bore	Kit	ZB	P	PA	Y	W	EE	YA	FH	UF	E1	E2	R	TF	FB
1-1/2"	MFFA-17 MFFS-17	4.62	2.28	2.58	1.67	.63	3/8 NPT	1.52	.38	3.38	2.00	2.00	1.43	2.75	.25
2"	MFFA-31 MFFS-31	4.62	2.28	2.58	1.67	.63	3/8 NPT	1.52	.38	4.12	2.34	2.50	1.84	3.38	.31
2-1/2"	MFFA-50 MFFS-50	4.75	2.41	2.70	1.67	.63	3/8 NPT	1.52	.38	4.62	2.94	3.00	2.19	3.88	.31
3-1/4"	MFFA-83 MFFS-83	5.63	2.62	3.00	2.19	.75	1/2 NPT	2.00	.62	5.50	3.69	3.75	2.76	4.69	.38
4"	MFFA-125 MFFS-125	5.63	2.62	3.00	2.19	.75	1/2 NPT	2.00	.62	6.25	4.44	4.50	3.32	5.44	.38

## Rear Flange Mount (NFPA MF-2) (in.)

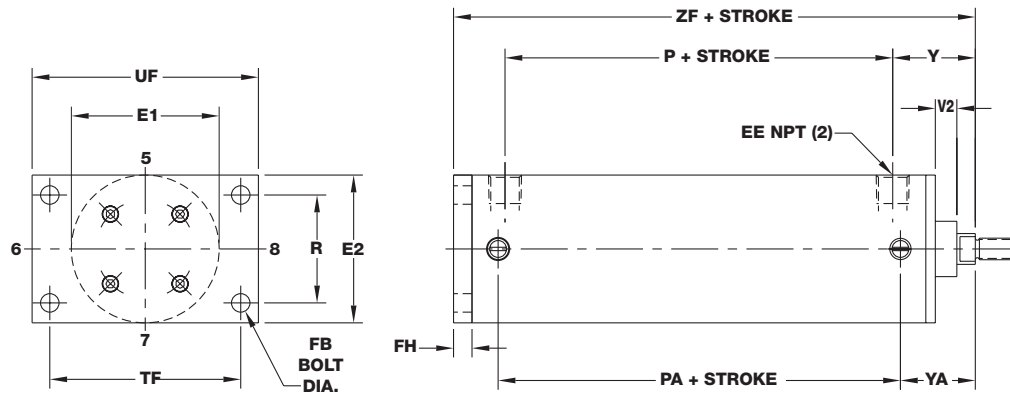

Bore	Kit	ZF	P	PA	Y	V2	EE	YA	FH	UF	E1	E2	R	TF	FB
1-1/2"	MFRA-17 MFRS-17	5.00	2.28	2.58	1.67	.44	3/8 NPT	1.52	.38	3.38	2.00	2.00	1.43	2.75	.25
2"	MFRA-31 MFRS-31	5.00	2.28	2.58	1.67	.44	3/8 NPT	1.52	.38	4.12	2.34	2.50	1.84	3.38	.31
2-1/2"	MFRA-50 MFRS-50	5.12	2.41	2.70	1.67	.44	3/8 NPT	1.52	.38	4.62	2.94	3.00	2.19	3.88	.31
3-1/4"	MFRA-83 MFRS-83	6.25	2.62	3.00	2.19	.74	1/2 NPT	2.00	.62	5.50	3.69	3.75	2.76	4.69	.38
4"	MFRA-125 MFRS-125	6.25	2.62	3.00	2.19	.74	1/2 NPT	2.00	.62	6.25	4.44	4.50	3.32	5.44	.38



# Bimba Double-Wall® Cylinders

## Double End Rod Cylinder Series DWD (in.)



Double-Wall Cylinders

Repairable Stainless Steel Cylinders

### Basic Double-End Rod Cylinder

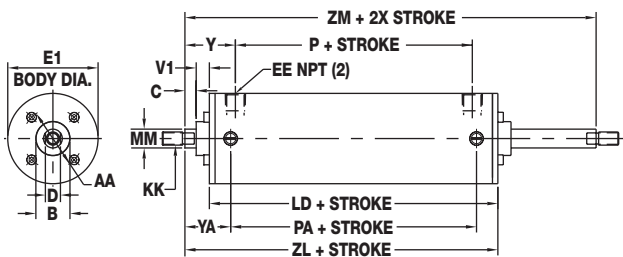

### Flange Mount (NFPA MF-1)

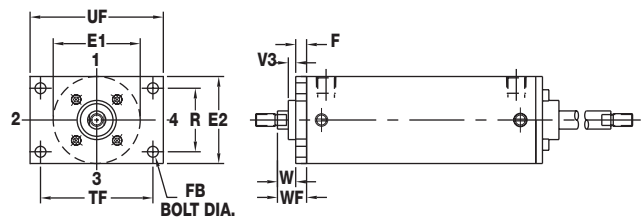

Mounting Kit # MFF (See page 6.4 for pricing)

### Side Lug Mount (NFPA MS-2)

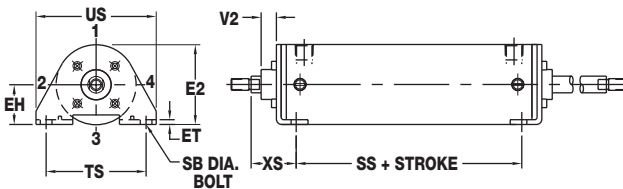

Mounting Kit # MSL (See page 6.4 for pricing)

### End Lug Mounts (NFPA MS-7)

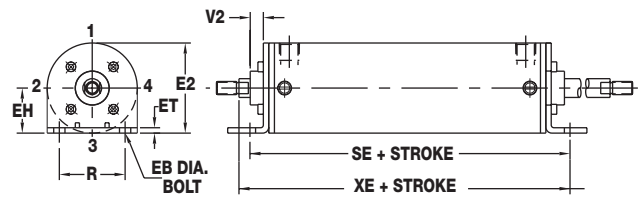

Mounting Kit # MEL (See page 6.4 for pricing)

Bore	AA	B	C	D	EB	EE	EH	ET	E1	E2	F	FB	KK	LD	MM	P	PA	R
1-1/2"	1.48	1.124	.38	.56	.25	3/8	1.00	.13	2.00	2.00	.38	.25	7/16-20	4.16	.62	2.44	2.74	1.43
2"	1.75	1.124	.38	.56	.31	3/8	1.25	.13	2.34	2.50	.38	.31	7/16-20	4.16	.62	2.44	2.74	1.84
2-1/2"	2.00	1.124	.38	.56	.31	3/8	1.49	.18	2.94	3.00	.38	.31	7/16-20	4.16	.62	2.44	2.74	2.19
3-1/4"	2.83	1.499	.50	.88	.38	1/2	1.87	.25	3.69	3.75	.62	.38	3/4-16	4.64	1.00	2.75	3.12	2.76
4"	2.83	1.499	.50	.88	.38	1/2	2.24	.31	4.44	4.50	.62	.38	3/4-16	4.64	1.00	2.75	3.12	3.32
Bore	SB	SE	SS	TF	TS	UF	US	V1	V2	V3	W	WF	XE	XS	Y	YA	ZL	ZM
1-1/2"	.38	5.46	3.22	2.75	2.75	3.38	3.51	.44	.31	.25	.62	1.00	5.72	1.38	1.67	1.52	4.96	5.77
2"	.38	5.84	3.22	3.38	3.25	4.12	4.01	.44	.31	.25	.62	1.00	5.90	1.38	1.67	1.52	4.96	5.77
2-1/2"	.38	6.10	3.22	3.88	3.75	4.62	4.51	.44	.26	.25	.62	1.00	6.03	1.38	1.67	1.52	4.96	5.77
3-1/4"	.50	6.26	3.51	4.69	4.75	5.50	5.76	.74	.49	.25	.75	1.37	6.76	1.88	2.19	2.00	5.89	7.13
4"	.50	6.51	3.51	5.44	5.50	6.25	6.51	.74	.43	.25	.75	1.37	6.89	1.88	2.19	2.00	5.89	7.13

Note: When ordering Cushions Both Ends specify DWDC – One End DWDS, See page 6.3.  
EE will provide extra extension on both ends.

# Bimba Double-Wall® Cylinders

## Double-Wall® Front Nose Mounting (in.)

### Single End Rod

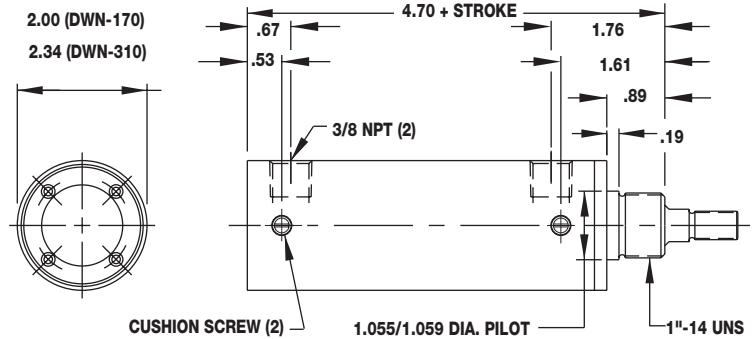

### Double End Rod

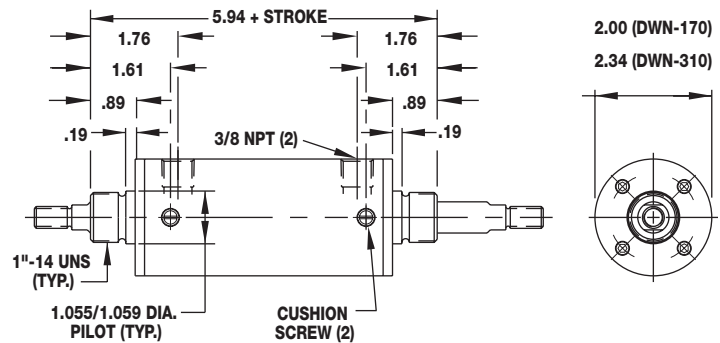

### Foot Bracket (D-17920) Accessory for Nose Mount

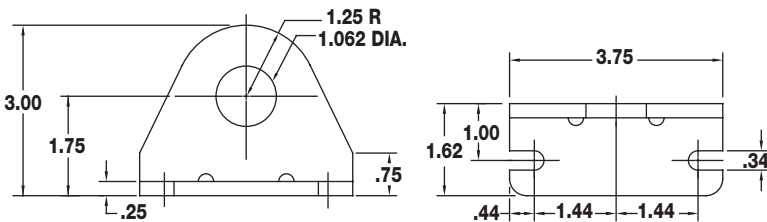

### Mounting Nut (D-1331)

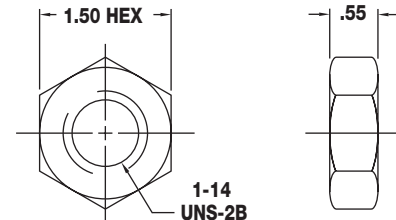

## Double-Wall Engineering Specifications

- Tie Tube:** Epoxy coated Aluminum
- Cylinder Body:** Smooth 304 stainless steel
- Piston Rod:** Hard Chrome Plated standard; 303 stainless optional
- Seals:** Buna N Standard; High Temperature Fluoroelastomer optional
- Lubrication:** Factory pre-lubed for non-lube service
- Temperature:** -20° to 200°F standard; 0° to 300°F with high temperature option
- Pressure Rating:** 200 psi; 150 psi with high temperature option
- Life:** 1400 miles of travel when lubricated (Lubrication every 500 miles recommended)
- Stroke Maximum:** 72" (strokes beyond 72" require an application review)

# Bimba Double-Wall® Cylinders

## Double-Wall® Long Stroke Cylinder Selection

Application of **Long Stroke Cylinders** are controlled by two factors: column strength of piston rod and mounting configuration. **Dual Piston** construction provides needed additional bearing surface through the cycle of the cylinder.

**Dual Pistons** consist of mounting two pistons on the rod, separated a calculated distance to provide the required stop length. Available in one inch increments, required stop lengths are determined from mounting class and stroke information.

### Determining Mounting Class

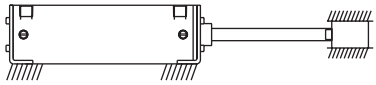
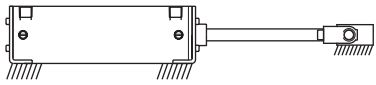
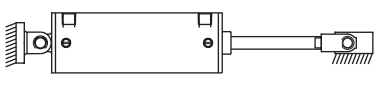
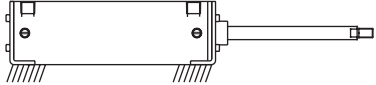
	Mounting Style	Rod End Connection
<b>Class 1</b> 	Side Lug End Lug Flange	Rigidly guided, pivoted
<b>Class 2</b> 	Side Lug End Lug Flange	Pivoted, supported but not rigidly guided
<b>Class 3</b> 	Pivot Clevis	Pivoted, supported
<b>Class 4</b> 	Side Lug End Lug Flange	Free end unguided and unsupported

### Dual Piston Stop Length Calculation

Select mounting class. Move over to the column showing a stroke length equal to or less than required. Figure at top of column is required Dual Piston stop length. Examples: Class 2, 62" stroke length = 2" stop length. Class 3, 62" - 5" stop length. All lengths shown here are in inches.

Mounting Class	Dual Piston - Stop Length Required											
	1	2	3	4	5	6	7	8	9	10	11	12
1	64	88	1.10	130								
2	46	62	78	93	108	122	136					
3	25	34	43	51	59	67	74	81	88	95	101	108
4	16	22	28	28	40	46	51	56	61	66	70	74

Net (effective) stroke stop length = Gross stroke of cylinder. Mounting dimensions are determined from gross stroke. Consult your local distributor for Dual Piston Pricing.

### Column Strength Limitations

Select mounting class, rod diameter, and stroke length in inches: read maximum push force in pounds for that combination. Where no value is shown, the rod is safe for the maximum rated cylinder push force.

Rod Diameter/ Inches Stroke	Class 1		Class 2		Class 3		Class 4	
	5/8"	1"	5/8"	1"	5/8"	1"	5/8"	1"
10							820	
15					820		360	2390
20					460		200	1340
25					290	1940	130	860
30			820		200	1340	90	600
40	820		460		110	750	50	330
50	540		290	1940	70	480	30	210
60	360	2390	200	1340	50	330	20	150

### Weights

Approximate Weights (lbs.)		
Bore	Base Weight	Adder per inch of stroke
1-1/2" (17)	1.36	0.19
2" (31)	1.81	0.22
2-1/2" (50)	2.9	0.31
3-1/4" (83)	5.62	0.51
4" (125)	7.5	0.57

# Bimba Double-Wall® Cylinders

## Accessories

### Rod Eye

Bore	Part #
1½ - 2½	ARE-1
3¼ - 4	ARE-2

(For -2 Rod End style only)

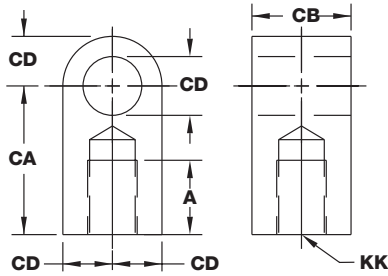

### Rod Stud

(Rolled Threads)

Bore	Part #
1½ - 2½	ARS-1
3¼ - 4	ARS-2



### Rod Clevis

Bore	Part #
1½ - 2½	ARC-1
3¼ - 4	ARC-2

(Nickel Steel)  
Includes Case Hardened Pin  
(For -2 Rod End style only)

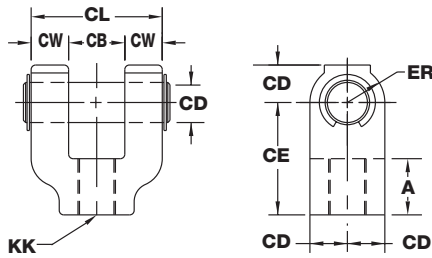

### Case Hardened Pivot Pin with Rings

Bore	Part #
1½ - 2½	APP-1
3¼ - 4	APP-2

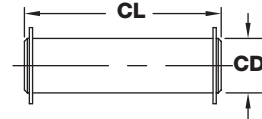

### Pivot Bracket

Bore	Part #
1½ - 2½	APB-1
3¼ - 4	APB-2

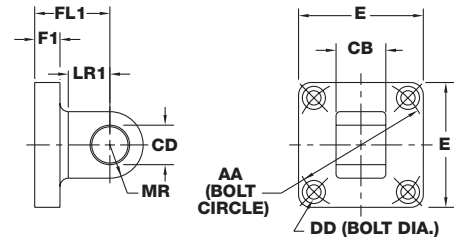

### Hex Nut (in.)

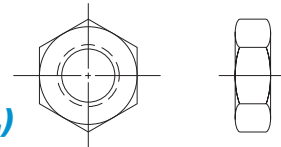

Part	Hex	THD	THK
D-154	0.69	7/16"-20	0.25
D-98	0.75	1/2"-20	0.31
D-3556	1.12	3/4"-16	0.42
D-2545	1.31	7/8"-14	0.48

### Clevis Bracket

Bore	Part #
1½ - 2½	ACB-1
3¼ - 4	ACB-2

(Includes Case Hardened Pin)

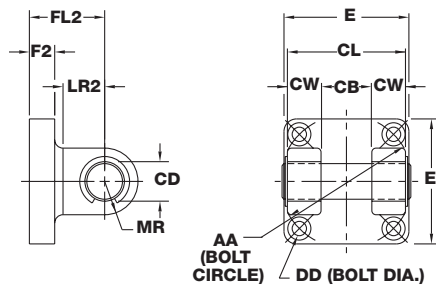

### Accessories Dimensions (in.)

Bore	A	AA	CA	CB	CD	CE	CW	CL	DD		
1-1/2", 2", 2-1/2"	0.75	2	1.5	0.75	0.5	1.5	0.5	1.75	0.19		
3-1/4", 4"	1.12	2.83	2.06	1.25	0.75	2.38	0.62	2.5	0.312		
Bore	E	ER	F1	F2	FL1	FL2	KK	KL	LR1	LR2	MR
1-1/2", 2", 2-1/2"	1.88	0.59	0.38	0.38	1.12	1.12	7/16" -20	2.12	0.745	0.745	0.5
3-1/4", 4"	2.75	0.84	0.5	0.38	1.88	1.25	3/4" - 16	3.27	1.1	0.85	0.69

# Bimba Double-Wall® Cylinders

## How to Order Repair Parts & Kits

### Basic DW Series

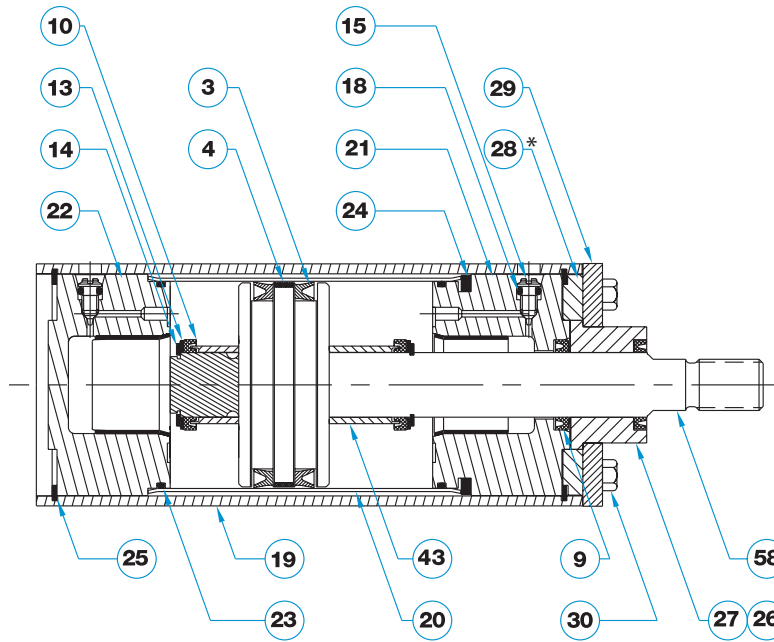

\* Used in most mounting kits and on all 3-1/4" and 4" bore basic cylinders.

### Basic DWD Series

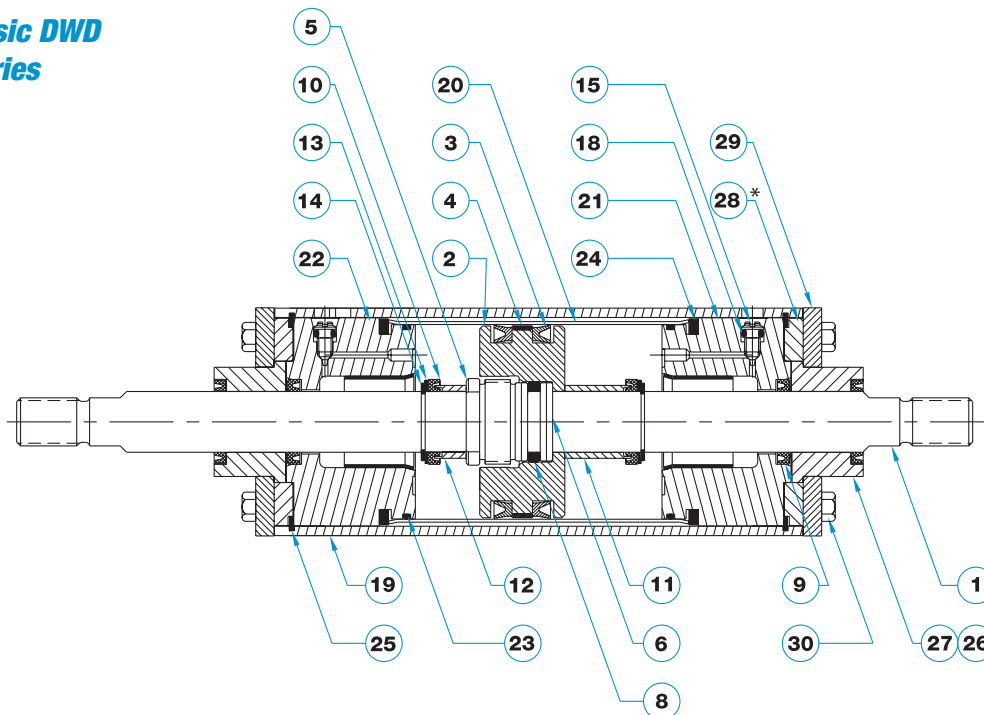

\* Used on all 3-1/4" and 4" bore basic cylinders.

Individual Repair Parts and Kits are listed on page 6.14. When ordering, indicate the quantity desired, the part number or kit designation, and the cylinder model number on which the part is to be used. For example, a Cushion Adjusting Screw for a 1-1/2" bore, 10" stroke, Double-Wall cylinder, Cushioned Both Ends, and a Small Male One Piece Rod End, would be ordered as follows:

	<u>Quantity</u>	<u>Part or Kit Number</u>	<u>Model Number</u>
	1	P-15	DWC-1710-2
A Basic Repair Kit for the same cylinder would be:	1	K-B	DWC-1710-2

See page 6.14 for Repair Parts and page 6.4 for Repair Kits Pricing.

# Bimba Double-Wall® Cylinders

## Repair Parts List

No.	Part Description	Quantity by Model Type						
		DW	DWF	DWR	DWC	DWD	DWDF	DWDC
P-1	Rod					1	1	1
P-2	Piston					1	1	1
P-3	Piston Seal	2	2	2	2	2	2	2
P-4	Piston Bearing Ring	1	1	1	1	1	1	1
P-5	Free Thread Nut*					1	1	1
P-6	Free Thread Ring*					4	4	4
P-8	O-Ring (Free Thread)*					1	1	1
P-9	Rod Seal*	1	1	1	1	2	2	2
P-10	Cushion Seal*		1	1	2		1	2
P-11	Cushion Sleeve (Head End)*						1	1
P-12	Cushion Sleeve (Cap End)*							1
P-13	Cushion B/U Washer*		1	1	2		1	2
P-14	Cushion Retaining Ring*		1	1	2		1	2
P-15	Cushion Adjusting Screw		1	1	2		1	2
P-18	O-Ring (Cushion Screws)*		1	1	2		1	2
P-19	Tie-Tube	1	1	1	1	1	1	1
P-20	Stainless Steel Body	1	1	1	1	1	1	1
P-21	Head	1	1	1	1	2	2	2
P-22	Cap	1	1	1	1			
P-23	O-Ring (Stainless Steel Body)	2	2	2	2	2	2	2
P-24	Wave Spring	1	1	1	1	2	2	2
P-25	Retaining Ring (Tie-Tube)	2	2	2	2	2	2	2
P-26	Rod Wiper (w/o Bushing)*	1	1	1	1	2	2	2
P-27	Rod Wiper Bushing Assembly*	1	1	1	1	2	2	2
P-28	Spacer	1	1	1	1	2	2	2
P-29	Retaining Plate	1	1	1	1	2	2	2
P-30	Screw (Ret. Plate)	4	4	4	4	8	8	8
P-43	Cushion Sleeve		1	1	2			
P-58	Piston/Rod Assembly	1	1	1	1			
HT-99-7CC	Lubrication	1	1	1	1	1	1	1
Mag-G-3CC	Polymer Grease Lubricant	1	1	1	1	1	1	1

\* Parts and kits that are common to multiple bore sizes, which are available in two sizes: 1-1/2", 2", 2-1/2" bores are designated as -S. 3-1/4", 4" bores are designated as -L.

### Repair Kits

Basic Repair Kit (K-B- ) Includes:		
P-25	Retaining Ring (Tie-Tube)	2
P-23	O-ring	2
P-24	Wave Spring	1
P-3	Piston Seal	2
P-4	Piston Bearing Ring	1
DWD Basic Repair Kit (K-D- ) Includes:		
P-25	Retaining Ring (Tie-Tube)	2
P-23	O-ring	2
P-24	Wave Spring	2
P-3	Piston Seal	2
P-4	Piston Bearing Ring	1

Cushion Repair Kit (K-C- ) Includes:		
P-10	Cushion Seal	1
P-13	Cushion B/U Washer	1
P-14	Cushion Retaining Ring	1
P-15	Cushion Adjusting Screw	1
P-18	O-Ring (Cushion Screws)	1
Rod Seal Repair Kit (K-A- ) Includes:		
P-27	Rod Wiper Bushing Assembly	1
P-9	Rod Seal	1
MRS Piston Repair Kit (K-P-M- ) Includes:		
P-33	Piston Seal Assembly	1
P-34	Magnet	1
P-4	Piston Bearing Ring	1

# Bimba Double-Wall® Cylinders

## Important Double-Wall® Information

**Piston Rod Diameter** – 5/8" and 1" diameter rods are standard. These rods are made of high strength steel and are suitable for most applications. On long stroke, high thrust applications caution should be exercised and the column strength and stop length chart on page 6.11 should be reviewed.

**Material** – Hard chrome plated rods are supplied as standard on all models except 1-1/2" MRS, which are 303 stainless steel. Special materials such as 303 stainless steel are available on request.

**Rod End Options** – Bimba offers six popular NFPA rod end styles (see page 6.5). Bimba considers the one-piece male style #2, as the primary standard rod end. A small male rod stud, style #2S, is also offered as a standard option. The stud is made from 125,000 P.S.I. min. yield steel and is roll threaded for increased strength. Special rod ends with different thread lengths, pitch and class are available upon request.

**Cushions** – The Double-Wall® offers exclusive Stainless-Cushions®, type 304 stainless steel sleeves which enhance cushion performance and life. The cushion seal is contained on the piston rod for easy inspection and replacement when necessary. Air cushions may be specified on either or both ends without changing the cylinder's overall length.

The cushion design allows for a flush mounted adjustment screw even in the fully open setting. Unless otherwise specified, cushioned models are shipped with the adjustment screws located in positions 4 and 8 as shown on the cylinder dimensional drawings.

Adjustment screws may be ordered in other than standard positions at no additional charge. Simply add these designations as the last digits of the model number:

- A2 – Head Adjustment Screw – Position 2
- A3 – Head Adjustment Screw – Position 3
- A6 – Cap Adjustment Screw – Position 6
- A7 – Cap Adjustment Screw – Position 7
- A26 – Adjustment Screws – Positions 2 and 6
- A37 – Adjustment Screws – Positions 3 and 7

**Mountings** – Double-Wall cylinders utilize easy to assemble "bolt on" mounting kits. Basic cylinders (less mountings) and mounting kits are ordered and shipped as separate items. All necessary hardware is contained in the kit. The clevis mounting kit for example contains the clevis cap, pivot pin, retaining rings, and mounting cap screws.

The clevis and pivot caps are high strength aluminum die castings and have oil-filled bronze bushings. Side and end lug kits contain brackets which are stamped from high strength steel. Flange kits are offered in both steel and aluminum. All mountings are epoxy coated.

"Bolt on" Double-Wall mounting kits give your local BIMBA Distributor inventory versatility allowing him to stock Basic cylinders of various popular strokes and bores without committing them exclusively to one mounting style. This means greater "off the shelf" availability for you.

**Delivery** – Ordering standard cylinders with the primary standard style #2 rod end will allow you to take advantage of a substantial local Distributor stock of Double-Wall cylinders. A very large stock of cushioned (both ends) and non-cushioned finished cylinders is always maintained at our Monee, Illinois plant. In addition we maintain a vast inventory of finished heads, caps, rods, etc. for quick assembly of your optional feature or non-standard stroke requirement.

**Specials** – Bimba Manufacturing welcomes the opportunity to custom design a cylinder to meet your exact specifications and requirements. As a leading manufacturer of custom special cylinders, we can provide the engineering expertise to help you with whatever design problem you face. We also maintain a specials department within our manufacturing facilities to assure you of the most expedient delivery possible. Please contact your local Bimba Distributor or Customer Service Department with details of your special requirement.

# Bimba Repairable Stainless Steel Cylinders

## Component Description

1. Rod Guide: Corrosion resistant 303 stainless steel is ideal for washdown applications. Designed specifically to reduce sharp edges and corners and provide a smooth transition to the cylinder body eliminating catch points for contamination and to allow ease in cleaning. Tapped holes are provided to allow easy mounting of USDA approved secondary wiper retainer as an option.
2. Rod Bushing: Material is PTFE (Polytetrafluoroethylene) for extended life, larger bores (5", 6", 8") utilize an acetal bushing.
3. Rod Wiper: A Urethane rod wiper is standard (high temperature material is optional) and offers resistance to a wide variety of washdown chemicals. Larger bores offer a PTFE rod wiper as standard.
4. Rod Seal: Nitrile rod seal (high temperature material is optional) is pressure activated and wear compensating for long life.
5. Body Seal: Nitrile material is standard (high temperature material is optional).
6. Body: Thick walled 316 stainless steel offers superior corrosion resistance and is designed to minimize gaps with the mating end caps where contamination can build up.
7. Rear Head: Corrosion resistant 303 stainless steel is ideal for washdown applications. Designed specifically to reduce sharp edges and corners and provide a smooth transition to the cylinder body eliminating catch points for contamination and to

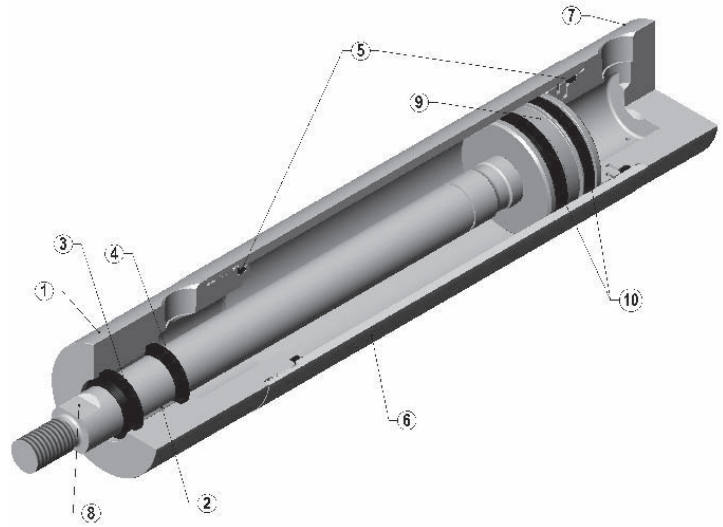

- allow ease in cleaning. Optional tapped holes allow for easy mounting of NFPA rear pivot or rear clevis mounting brackets.
8. Piston Rod: Ground and roller burnished 303 stainless steel for maximum corrosion resistance.
  9. Piston: Precision machined from aluminum (optional bearing strip) may also be ordered in stainless steel for internal corrosion resistance when required.
  10. Piston Seals: Nitrile material is standard, high temperature material is optional. Seals are pressure activated and wear compensating.
  11. Lubricant: Food Grade (H1) Grease.

## Operating Specifications

- Temperature:** -20° to 200°F standard; 0° to 400°F with V option  
**Stroke Maximum:** 24" (strokes beyond 24" require an application review)  
**Operating Pressure:** 200 psi maximum

## USDA Accepted (Option U, see page 6.17 and 6.20)

## EQUIPMENT ACCEPTANCE CERTIFICATE

The issuance of this form is based on U.S. Department of Agriculture, Dairy Grading Branch, Equipment Design Review Section, evaluation of the equipment listed above for compliance with:

USDA Dairy Equipment Guidelines



# Bimba Repairable Stainless Steel Cylinders

## How to Order

### RS - 1-1/2 X 4 - MP2 U

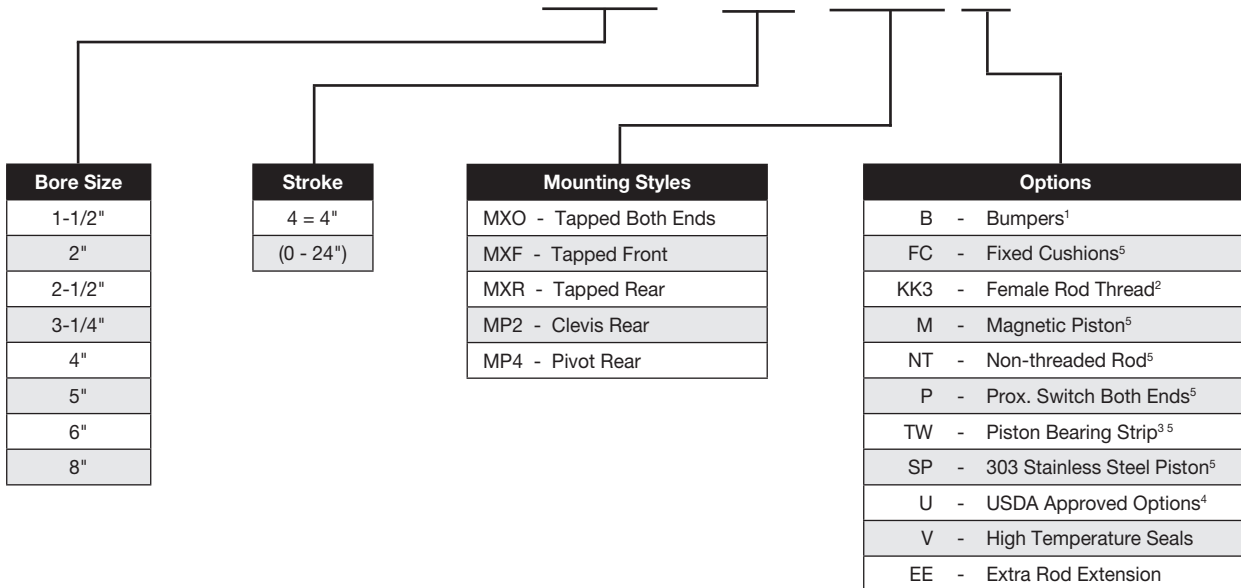

#### Option Notes:

Option (B) Bumpers and Option (FC) Cushions are not a valid combination.  
 Option (B) Bumpers and Option (P) Prox. Switches are not a valid combination.  
 If Option (B) and Option (V) are ordered in combination, the standard Bumper material will be used in bore sizes 5, 6, and 8".  
 Option (M) Magnetic Piston and Option (V) High Temperature Seals should be specified for chemical compatibility requirements only. The piston magnet is nitrile based, hence the temperature rating remains at 200 degrees F.

## List Prices

Bore	Tapped Both Ends (MXO)	Tapped Front (MXF)	Tapped Rear (MXR)	Rear Clevis (MP2)	Rear Pivot (MP4)	Adder per 1" Stroke	Bumpers Both Ends (B) <sup>1</sup>	Fixed Cushions (FC) <sup>5</sup>	Magnetic Piston (M) <sup>5</sup>	Prox Switches (P) <sup>5</sup>	Piston Bearing Strip (TW) <sup>3,5</sup>	303 SS Piston (SP) <sup>5</sup>	USDA Options (U) <sup>4</sup>	High Temp Seals (V)	Extra Rod Ext. (EE)
1-1/2" (17)	\$338.05	\$321.15	\$321.15	\$433.60	\$429.90	\$10.40	\$11.35	\$63.00	\$22.25	\$252.95	\$14.05	\$43.05	\$129.40	\$37.40	\$6.00/inch
2" (31)	379.55	362.70	362.70	481.50	476.35	13.85	17.90	69.20	25.90	252.95	14.85	49.15	134.10	43.30	6.00/inch
2-1/2" (50)	412.35	395.50	395.50	520.25	513.55	15.50	17.90	77.50	25.90	252.95	15.40	49.90	135.60	47.70	6.00/inch
3-1/4" (83)	520.95	504.10	504.10	638.50	630.40	17.80	24.80	84.05	46.15	252.95	16.65	63.40	153.80	89.95	8.65/inch
4" (125)	605.05	588.20	588.20	731.05	721.55	23.25	24.80	91.65	53.40	252.95	17.90	72.60	164.70	98.10	8.65/inch
5"	892.05	882.75	882.75	1066.70	1068.40	25.80	28.55	85.65	52.55	N/A	22.05	79.15	234.80	165.00	8.05/inch
6"	1072.65	1061.40	1061.40	1288.25	1296.70	37.20	32.75	85.65	53.00	N/A	24.70	112.00	331.90	174.80	8.75/inch
8"	1326.40	1315.05	1315.05	1622.25	1624.85	52.05	32.75	85.65	53.00	N/A	30.45	200.80	408.80	287.90	8.75/inch

<sup>1</sup> Bumper adds 1/4" to overall length in bores 1-1/2" to 4". Bumper adds 1/2" in bores 5" to 8".

<sup>2</sup> Other rod ends available upon request. See page 6.21.

<sup>3</sup> Standard with Stainless Piston Option.

<sup>4</sup> USDA Approved option includes an external wiper as required by the USDA. The cylinder rod length will automatically increase by the amount required to accommodate the seal retaining bracket. See page 6.20.

<sup>5</sup> The following options do not affect length: Fixed Cushions (FC), Magnetic Piston (M), Non-threaded Rod (NT), Proximity Switches (P), Piston Bearing Strip (TW), and 303 Stainless Steel Piston (SP).

No Charge: (KK3) Female Rod Threads  
 (NT) Non-threaded Rod

# Bimba Repairable Stainless Steel Cylinders

## Accessories (All Stainless Steel)

Alignment Couplers				
100 psi air (max.) Operating Pressure				
Part No.	Price	Threads	Jam Nuts	
			Part No.	Price
AC250-SS	\$ 67.00	1/4"-28	D-344-SS	\$ 1.30
AC312-SS	80.05	5/16"-24	D-746-SS	1.30
AC375-SS	85.75	3/8"-24	D-801-SS	1.25
AC437-SS	104.65	7/16"-20	D-154-SS	1.75
AC500-SS	104.65	1/2"-20	D-98-SS	1.90
AC625-SS	111.55	5/8"-18	D-9-SS	2.50
AC750-SS	137.80	3/4"-16	D-3556-SS	3.25
AC875-SS	137.80	7/8"-14	D-2545-SS	5.90
AC1000-SS	215.50	1"-14	D-1331-SS	3.90
AC1250-SS	215.50	1-1/4"-12	D-92067-SS	24.25

Clevis Brackets		
Part No.	Pin Dia.	Price
RS-CB500	1/2"	\$124.70
RS-CB750	3/4"	181.80
RS-CB1000	1"	233.60
RS-CB1375	1-3/8"	397.60

Clevis Pins		
Part No.	Pin Dia.	Price
RS-CP500	1/2"	\$ 14.45
RS-CP750	3/4"	24.10
RS-CP1000	1"	29.75
RS-CP1375	1-3/8"	43.25

Eye Brackets		
Part No.	Pin Dia.	Price
RS-EB500	1/2"	\$113.30
RS-EB750	3/4"	234.30
RS-EB1000	1"	325.90
RS-EB1375	1-3/8"	454.85

Foot Brackets*		
Part No.	Bore	Price
RS-FB150	1-1/2"	\$ 49.15
RS-FB200	2"	53.30
RS-FB250	2-1/2"	55.35
RS-FB325	3-1/4"	58.70
RS-FB400	4"	59.75
RS-FB500	5"	60.05
RS-FB600	6"	92.10
RS-FB800	8"	118.85

\*Must be ordered with MXO cylinder  
Pair, fasteners included

Rod Clevis		
Part No.	Threads	Price
RS-RC437	7/16"-20	\$ 44.00
RS-RC500	1/2"-20	44.00
RS-RC750	3/4"-16	102.60
RS-RC1000	1"-14	185.40
RS-RC1250	1-1/4"-12	295.40

Rod Eye		
Part No.	Threads	Price
RS-RE437	7/16"-20	\$ 24.25
RS-RE500	1/2"-20	24.25
RS-RE750	3/4"-16	59.35
RS-RE1000	1"-14	97.10
RS-RE1250	1-1/4"-12	149.80

## Dimensions for Mounting Styles MXO, MXR, MXF (inches)

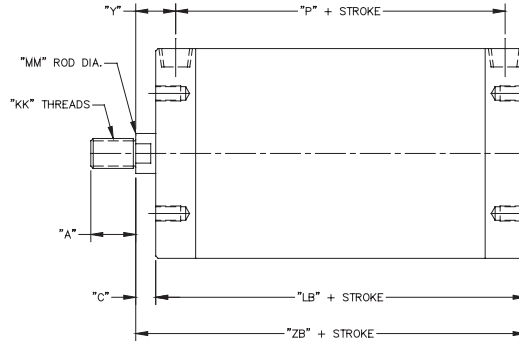
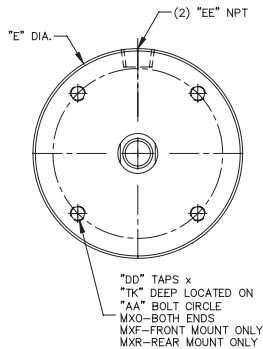

Bore	Rod Diameter	A	AA	C	DD	E Dia.	EE NPT	KK	LB	MM	TK	Y	P	ZB
1-1/2"	5/8"	3/4	1.45	.56	10-24	1.75	3/8	7/16-20	5.21	5/8	.33	1.99	3.16	5.77
2"	5/8"	3/4	1.85	.56	10-24	2.25	3/8	7/16-20	5.45	5/8	.38	1.94	3.15	6.01
2-1/2"	5/8"	3/4	2.15	.56	1/4-20	2.75	3/8	7/16-20	5.95	5/8	1/2	1.93	3.39	6.51
3-1/4"	1"	1-1/8"	2.62	.64	5/16-18	3.50	1/2	3/4-16	7.43	1	5/8	2.64	3.83	8.07
4"	1"	1-1/8"	3.25	.64	3/8-16	4.25	1/2	3/4-16	7.43	1	3/4	2.52	3.93	8.07
5"	1"	1-1/8"	4.25	.50	3/8-16	5.25	1/2	3/4-16	5.75	1	5/8	1.00	4.75	6.25
6"	1-3/8"	1-5/8"	5.00	.63	1/2-13	6.25	1/2	1-14	5.75	1-3/8	7/8	1.13	4.75	6.38
8"	1-3/8"	1-5/8"	6.50	.63	5/8-11	8.38	1/2	1-14	5.88	1-3/8	1	1.13	4.88	6.50

Note: Oversized rods are available in 5", 6", and 8" bore in each mounting style. Please contact distributor.

# Bimba Repairable Stainless Steel Cylinders

## Clevis Mount (MP2) (inches)

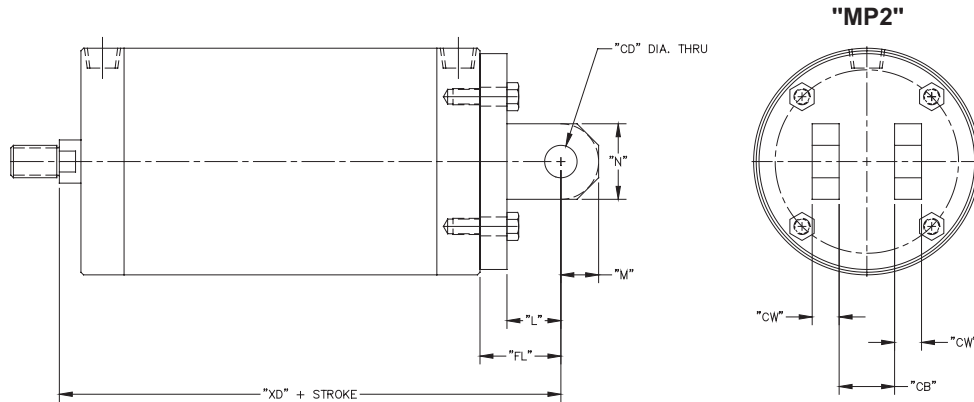

Bore	Rod Diameter	CB	CD	CW	FL	L	M	N	XD
1-1/2"	.63	.75	.50	.49	1.13	.75	.35	.70	6.90
2"	.63	.75	.50	.50	1.13	.75	.40	.80	7.14
2-1/2"	.63	.75	.50	.50	1.13	.75	.40	.80	7.64
3-1/4"	1.00	1.25	.75	.63	1.88	1.25	.60	1.00	9.94
4"	1.00	1.25	.75	.63	1.88	1.25	.75	1.40	9.94
5"	1.00	1.25	.75	.63	1.88	1.25	.88	1.75	8.13
6"	1.38	1.50	1.00	.75	2.25	1.50	1.00	2.00	8.63
8"	1.38	1.50	1.00	.75	2.25	1.50	1.00	3.50	8.75

Note: Oversized rods are available in 5", 6", and 8" bore in each mounting style. Please contact distributor.

## Pivot Mount (MP4) (inches)

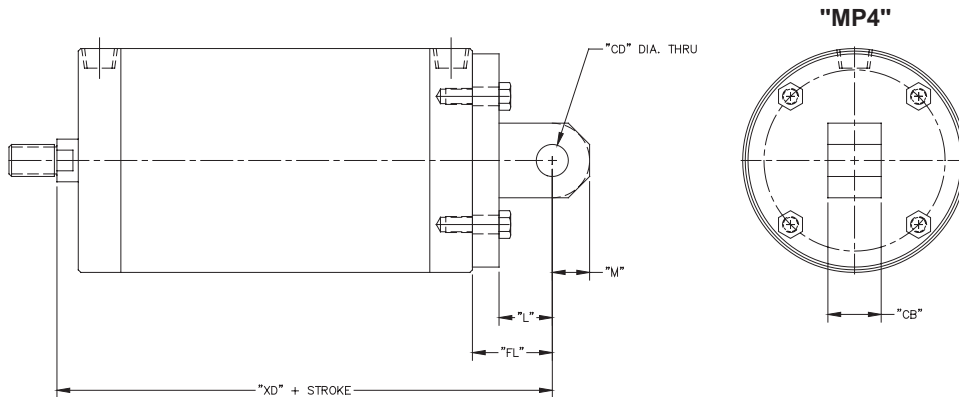

Bore	Rod Diameter	CB	CD	FL	L	M	N	XD
1-1/2"	.63	.75	.50	1.13	.75	.35	.70	6.90
2"	.63	.75	.50	1.13	.75	.40	.80	7.14
2-1/2"	.63	.75	.50	1.13	.75	.40	.80	7.64
3-1/4"	1.00	1.25	.75	1.88	1.25	.60	1.00	9.94
4"	1.00	1.25	.75	1.88	1.25	.75	1.40	9.94
5"	1.00	1.25	.75	1.88	1.25	.88	1.75	8.13
6"	1.38	1.50	1.00	2.25	1.50	1.00	2.00	8.63
8"	1.38	1.50	1.00	2.25	1.50	1.00	3.50	8.75

Note: Oversized rods are available in 5", 6", and 8" bore in each mounting style. Please contact distributor.

# Bimba Repairable Stainless Steel Cylinders

## USDA Approved Option "U" (inches)

1-1/2" to 4" Bores

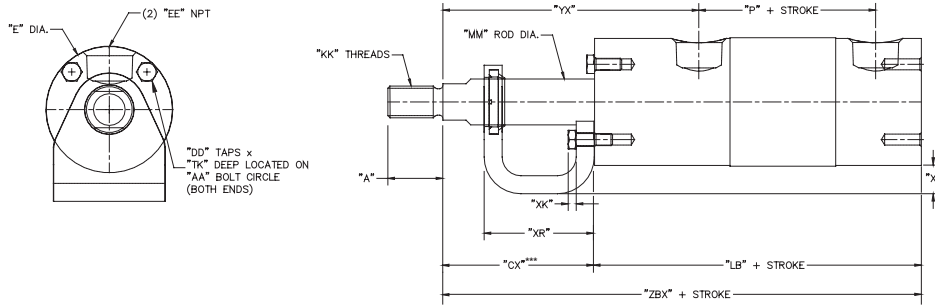

5", 6", and 8" Bores

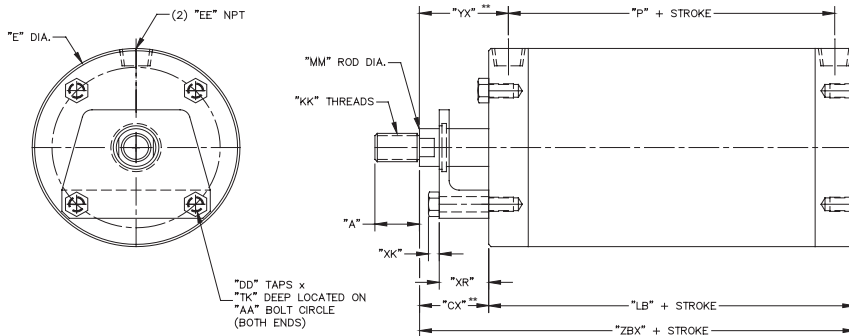

### External Wiper (Option U) Dimensions

Bore	Rod Diameter	A	AA	CX	DD	E Dia.	EE NPT	KK	LB	MM	TK	YX	P	XR	XK	ZBX	X
1-1/2"	.63	3/4	1.45	2.06	8-32	1-3/4	3/8	7/16-20	5.21	5/8	.33	3.49	3.16	1.50	.10	7.27	.38
2"	.63	3/4	1.85	2.06	10-24	2-1/4	3/8	7/16-20	5.45	5/8	.38	3.44	3.15	1.50	.12	7.51	.50
2-1/2"	.63	3/4	2.15	2.06	1/4-20	2-3/4	3/8	7/16-20	5.95	5/8	1/2	3.43	3.39	1.50	.17	8.01	.26
3-1/4"	1.00	1-1/8	2.62	2.14	5/16-18	3-1/2	1/2	3/4-16	7.43	1	5/8	4.14	3.83	1.50	.24	9.57	.25
4"	1.00	1-1/8	3.25	2.14	3/8-16	4-1/4	1/2	3/4-16	7.43	1	3/4	4.02	3.93	1.50	.27	9.57	.25
5"	1.00	1-1/8	4.25	1.75	3/8-16	5-1/4	1/2	3/4-16	5.75	1	5/8	2.25	4.75	1.25	.27	7.50	N/A
6"	1.38	1-5/8	5.00	1.88	1/2-13	6-1/4	1/2	1-14	5.75	1-3/8	7/8	2.38	4.75	1.25	.36	7.63	N/A
8"	1.38	1-5/8	6.50	1.88	5/8-11	8-3/8	1/2	1-14	5.88	1-3/8	1	2.38	4.88	1.25	.44	7.75	N/A

Note: The USDA-approved option "U" includes an external wiper as required by the USDA. Cylinder length is increased as shown. Oversized rods are available in 5", 6", and 8" bore in each mounting style. Please contact distributor.

## Examples of "U" Option Mounting Bracket



# Bimba Repairable Stainless Steel Cylinders

## Foot Bracket Accessory (inches)

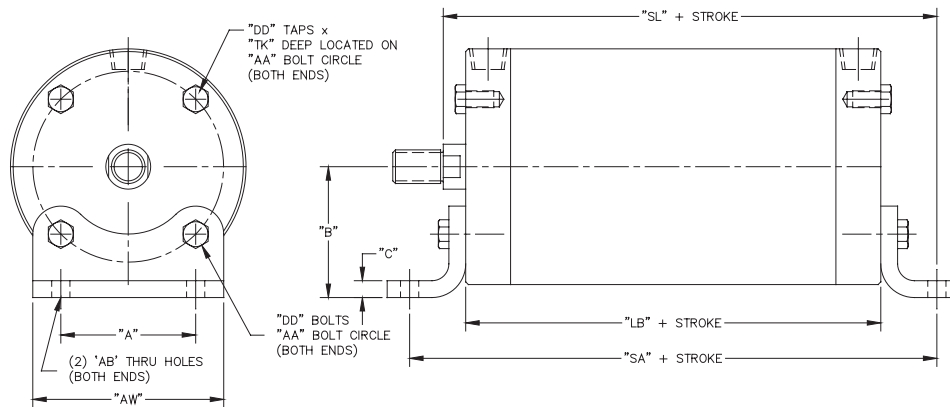

### RS Series Foot Mounting Brackets

Bore	Foot Bracket Kit	A	AB	AW	B	C	DD	AA	LB	TK	SA	SL
1-1/2"	RS-FB150	1.03	3/16	1.52	1.25	1/4	8-32	1.45	5.21	.38	6.62	6.46
2"	RS-FB200	1.31	7/32	1.81	1.62	1/4	10-24	1.85	5.45	.38	7.58	7.07
2-1/2"	RS-FB250	1.55	9/32	2.30	1.64	1/4	1/4-20	2.15	5.95	1/2	7.90	7.48
3-1/4"	RS-FB325	1.86	11/32	2.86	2.00	1/4	5/16-18	2.62	7.43	5/8	9.74	9.23
4"	RS-FB400	2.30	13/32	3.50	2.38	1/4	3/8-16	3.25	7.43	3/4	10.05	9.39
5"	RS-FB500	3.00	11/16	4.50	2.88	3/16	3/8-16	4.25	5.75	5/8	8.50	7.63
6"	RS-FB600	4.00	13/16	5.50	3.38	3/16	1/2-13	5.00	5.75	7/8	8.50	7.75
8"	RS-FB800	5.00	13/16	7.00	4.44	1/4	5/8-11	6.50	5.88	1	9.50	8.31

Notes: Foot bracket mounting kits include two brackets and eight stainless steel screws.  
Can only be applied to MXO mounting styles.

## Female Piston Rod End (Option KK3)

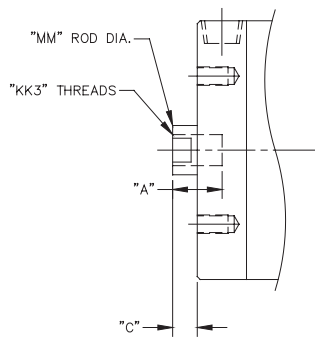

Bore	MM Rod Diameter	KK3	A (Thread Depth)	C
1-1/2", 2", 2-1/2"	5/8" Standard	7/16-20	3/4	.56
3-1/4", 4"	1" Standard	3/4-16	1-1/8	.64
5"	1" Standard	3/4-16	1-1/8	.50
6", 8"	1-3/8" Standard	1-14	1-5/8	.63

## Weights of Cylinders

Approximate Weights (lbs.)		
Bore	Base Weight	Adder per inch of stroke
1-1/2"	2.82	0.27
2"	5.25	0.33
2-1/2"	8.92	0.39
3-1/4"	20.63	0.61
4"	30.20	0.70
5"	24.10	0.84
6"	36.45	1.12
8"	69.80	1.80

# Bimba Repairable Stainless Steel Cylinders

## Stainless Steel Accessories (inches)

### Clevis Pin

Part No.	CD(+.000/ -.001)	LH	LP
RS-CP500	1/2	2-1/4	1-15/16
RS-CP750	3/4	3	2-23/32
RS-CP1000	1	3-1/2	3-7/32
RS-CP1375	1-3/8	5	4-1/4

Clevis Pin sold with (2) S.S. Cotter Pins

CLEVIS PIN (INCLUDES COTTER PINS)

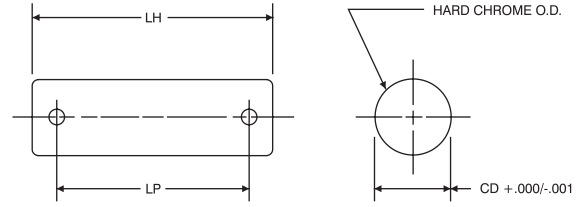

(Clevis Pins sold with (2) S.S. Cotter Pins)

### Rod Clevis

Part No.	CB	CD	CE	CW	ER	KK	L
RS-RC437	3/4	1/2	1-1/2	1/2	1/2	7/16-20	3/4
RS-RC500						1/2-20	
RS-RC750	1-1/4	3/4	2-3/8	5/8	3/4	3/4-16	1-1/4
RS-RC1000	1-1/2	1	3-1/8	3/4	1	1-14	1-1/2

Clevis Pins sold separately

ROD CLEVIS

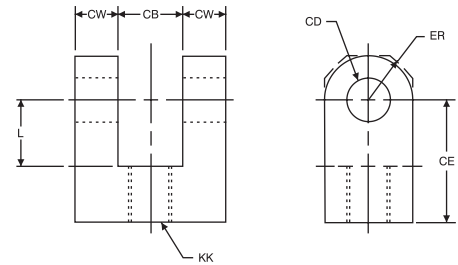

(Clevis Pins sold separately from Rod Clevis)

### Rod Eye

Part No.	A	CA	CB	CD	ER	KK
RS-RE437	3/4	1-1/2	3/4	1/2	5/8	7/16-20
RS-RE500						1/2-20
RS-RE750	1-1/8	2-1/16	1-1/4	3/4	7/8	3/4-16
RS-RE1000	1-5/8	2-13/16	1-1/2	1	1-13/16	1-14

Clevis Pins sold separately

ROD EYE

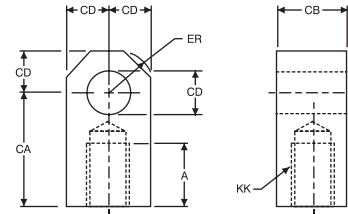

(Clevis Pins sold separately from Rod Eyes)

### Clevis Brackets and Eye Brackets

Part No.	BA	CB	CD	CW	DD	E	F	FL	L	M
<b>Clevis Brackets</b>										
RS-CB500	1-5/8	3/4	1/2	1/2	3/8-24	2-1/2	3/8	1-1/8	3/4	5/8
RS-CB750	2-9/16	1-1/4	3/4	5/8	1/2-20	3-1/2	5/8	1-7/8	1-1/4	3/4
RS-CB1000	3-1/4	1-1/2	1	3/4	5/8-18	4-1/2	3/4	2-1/4	1-1/2	1
RS-CB1375	3-13/16	2	1-3/8	1	5/8-18	5	7/8	3	2-1/8	1-3/8
<b>Eye Brackets</b>										
RS-EB500	1-5/8	3/4	1/2	N/A	13/32	2-1/2	3/8	1-1/8	3/4	1/2
RS-EB750	2-9/16	1-1/4	3/4		17/32	3-1/2	5/8	1-7/8	1-1/4	3/4
RS-EB1000	3-1/4	1-1/2	1		21/32	4-1/2	3/4	2-1/4	1-1/2	1
RS-EB1375	3-13/16	2	1-3/8		21/32	5	7/8	3	2-1/8	1-3/8

Clevis Pins sold separately

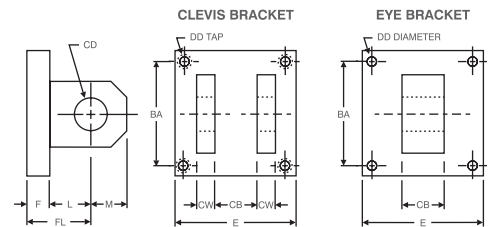

(Clevis Pins sold separately from Clevis & Eye Brackets)

Mounted to machine to interface with rod end access, and MP2/MP4.

# Bimba Repairable Stainless Steel Cylinders

## Stainless Steel Accessories Stainless Steel Alignment Couplers (inches)

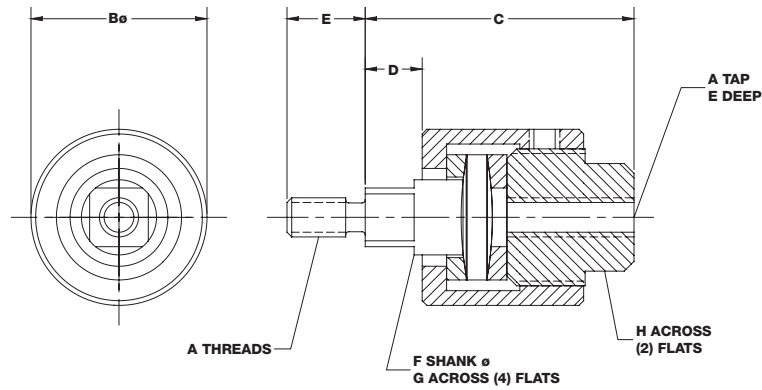

Part Number	A	B	C	D	E	F	G	H	Maximum Pull at Yield (lbs.)
AC250-SS	1/4-28	1-1/8	1-3/4	3/8	1/2	1/2	3/8	11/16	225
AC312-SS	5/16-24	1-1/8	1-3/4	3/8	1/2	1/2	3/8	11/16	375
AC375-SS	3/8-24	1-1/8	1-3/4	3/8	1/2	1/2	3/8	11/16	575
AC437-SS	7/16-20	1-1/4	2	7/16	3/4	5/8	1/2	13/16	800
AC500-SS	1/2-20	1-1/4	2	7/16	3/4	5/8	1/2	13/16	1100
AC625-SS	5/8-18	1-1/4	2	7/16	3/4	5/8	1/2	13/16	1750
AC750-SS	3/4-16	1-3/4	2-5/16	7/16	1-1/8	31/32	13/16	1-1/8	2600
AC875-SS	7/8-14	1-3/4	2-5/16	7/16	1-1/8	31/32	13/16	1-1/8	3550
AC1000-SS	1-14	2-1/2	2-15/16	7/16	1-5/8	1-11/32	1-5/32	1-5/8	4800
AC1250-SS	1-1/4-12	2-1/2	2-15/16	7/16	1-5/8	1-11/32	1-5/32	1-5/8	7600

## Examples of Specials Capability

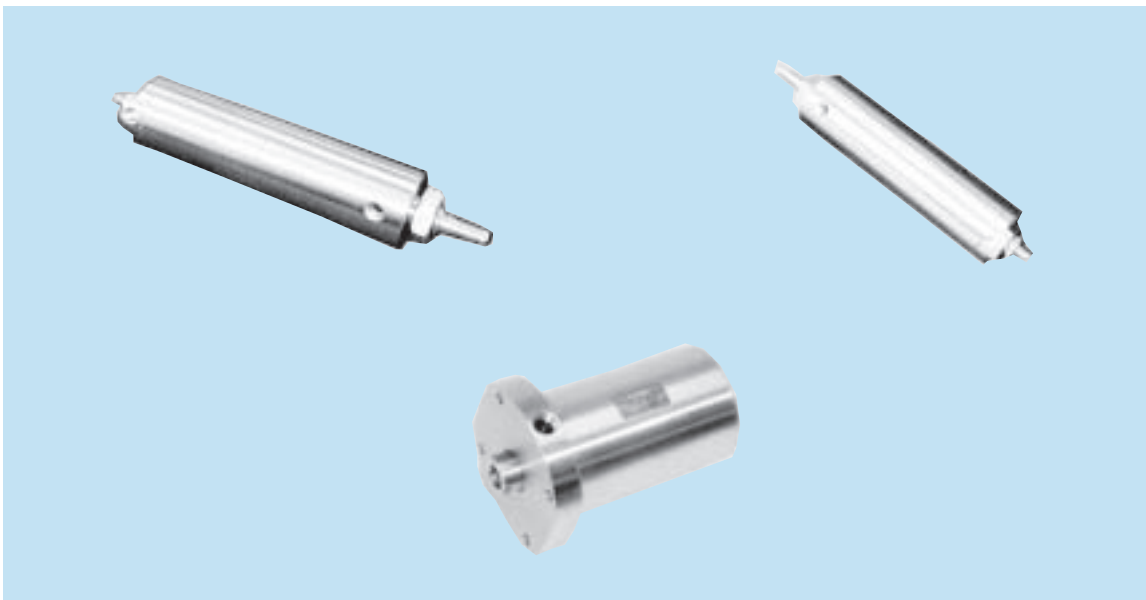

# Bimba Repairable Stainless Steel Cylinders

## Proximity Switch Option Dimensions (Option P)

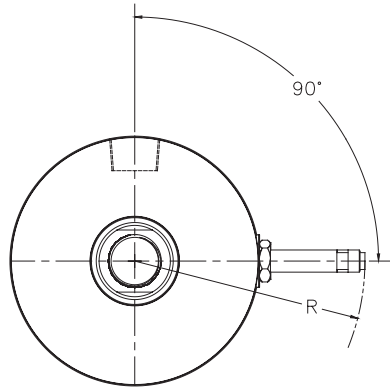

Bore Size	Dimension R
1-1/2"	3.04"
2"	3.04"
2-1/2"	3.04"
3-1/4"	3.19"
4"	3.19"
5"	N/A
6"	N/A
8"	N/A

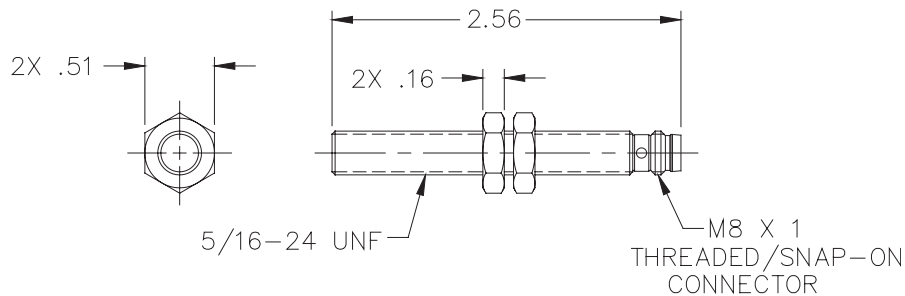

## Specifications

<b>Output:</b>	PNP Sourcing Output, normally open
<b>Load Current:</b>	100mA max.
<b>Leakage Current:</b>	10uA max.
<b>Voltage Drop:</b>	2 VDC
<b>Short Circuit and Overload Protection:</b>	yes
<b>Reverse Polarity Protection:</b>	yes
<b>Supply voltage:</b>	10-30 VDC
<b>LED:</b>	yes
<b>Current Consumption:</b>	15mA
<b>Repeatability:</b>	0.010° (.25mm)
<b>Hysteresis:</b>	5%
<b>Response Time:</b>	330uS
<b>Electromagnetic Compatibility Compliance:</b>	NEMA ICS5-1996
<b>Protection Class:</b>	IP67
<b>Ambient Temperature:</b>	-14°F to 158°F (-25°C to 70°C)
<b>Housing Material:</b>	Stainless steel
<b>Sensing Face:</b>	Crastin
<b>Approvals:</b>	UL-General Purpose CSA-General Purpose FM-Nonincendive